

HINGE PLACEMENT DETAIL

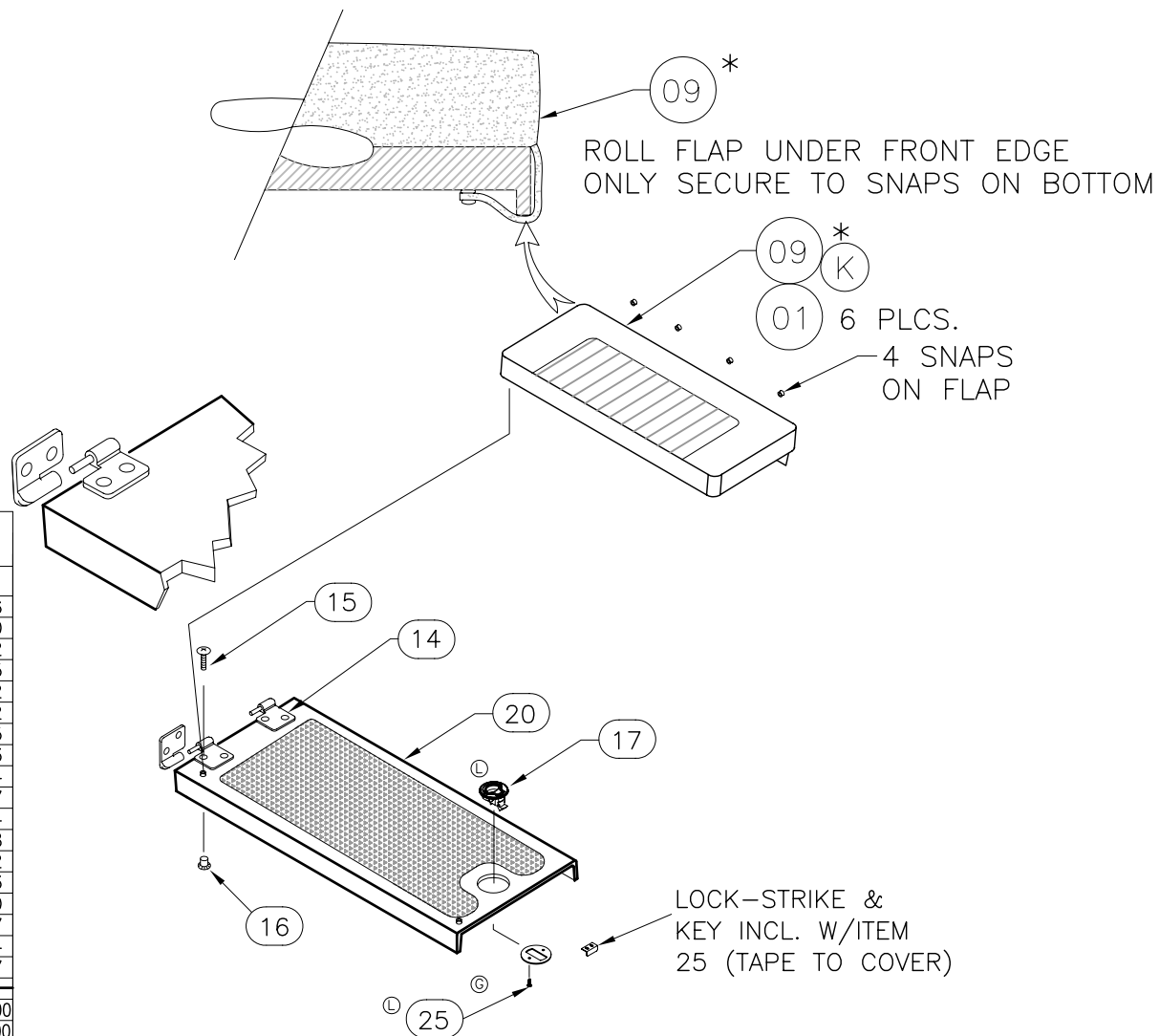

PARTS LIST

ITEM	QTY.	U/M	DESCRIPTION	B.W.I. NO.
(K) 1	22	EA.	SNAP STUD, W/#8 x 3/8" PH BR/NI/SS	0203786
2	3	EA.	CLIP, SUPPORT 1" DIA	1216720
3	3	EA.	SCREW, TAPPING #10A x 3/4" PTH SC	1008762
(K) 4	1	EA.	CUSH, BW150SP-05 BNCHST STB	1781375
(F) 5	3	EA.	SCREW, TAPPING #8A x 1/2" PTH SC	1008812
6	3	EA.	SCREW, TAPPING #10A x 3/4" POH SC	1010552
7	1	EA.	SUPPORT, HDPE BW150-02 SEAT SEAFOAM	1691285
(K) 8	1	EA.	CUSH, BW150SP-05 BNCHST PRT	1781373
(K) 9	1	EA.	CUSH, BW150SP-05 BNCHST PRT FWD	1781374
(K) 10	1	EA.	CUSH, BW130/150SP-05 BNCHST B/R PRT	1781367
11	1	EA.	ROD HOLDER, BW150SP-02 4-ROD ASSY WHT	1691124
(K) 12	1	EA.	CUSH, BW130/150SP-05 BNCHST B/R STB	1781368
13	1	EA.	POCKET, ABS BW150-02 STRG BNCHST	1691092
(EA) 14	1	PR.	HINGE, TAKE APART 316 SS LH	1727763
(F) 15	4	EA.	SCREW, MACHINE #10-24 X 3/4" POH SC	1008440
16	4	EA.	NUT, BBL #10-24 x 3/8" FH	1040187
(L) 17	1	EA.	LATCH, FLUSH MNT N/LOCKING SLAM SS	1781434
(K) 18	7	EA.	SNAP STUD, 1/8" X 1/2" ALUM	1040237
(E) 19	4	EA.	WASHER, FLAT #10 SC	1260751
20	1	EA.	FIBERGLASS PART, BENCH SEAT FWD	22-K101-00
21	1	EA.	FIBERGLASS PART, BENCH SEAT HELM	22-K102-00
(CFD) 22	3	EA.	SCREW, MACHINE #8-32 x 3/4" PTH SC	1010735
(F) 23	3	EA.	NUT, WING #8-32 NYLON	1103530
(F) 24	3	EA.	WASHER, FLAT #8 SC	1326297
(L) 25	1	EA.	PLATE, FLAT BRKT 2"SHORT SCREW W/HDWR PKG.	1781436